

## Baty R14 - Profile Projector

The Baty R14 bench mount profile projector with its 340mm screen combines high accuracy non-contact measurement and inspection with a large 175mm x 100mm measuring range.

Choice of digital readouts and optional automatic profile edge detection. The horizontal light path configuration is ideally suited to machined parts that can be secured to the workstage using a range of optional accessories from the Baty fixture family. The compact and robust lightweight chassis makes the R14 ideal for workshop environments.

### Features

- 340mm (14") screen with 90° crosslines and chart clips
- Profile illumination with halogen lamp and green filter
- Lens magnification choice: 10x, 20x, 25x, 50x and 100x
- Surface illumination (fibre optic)
- Helix adjustment of light source  $\pm 7^\circ$  for accurate thread form projection
- Workstage with machined slot for holding accessories
- Workstage measuring range of 175mm (7") x 100mm (4")
- Digital angle measurement to 1 minute
- 10x lens included
- 0.5 micron resolution

### Available Options

- Internally fitted automatic edge sensor
- Swing over lamphouse to allow clear access to the workstage
- Various electronic measuring systems to suit individual requirements
- Cabinet stand ensures a solid base and provides storage
- Other options include foot switch control and printer



R14-GMR



Projector Type	R14				
Magnification	10x	20x	25x	50x	100x
Field of view	35	18	14	7	4
Working Distance	81	38	28	15	31
Maximum	half field	103	103	80	45
Working Diameter	full field	120	109	56	31
				31	77

### LENS SYSTEMS

Code No	Description
122-600	Lens system - magnification 10x
122-601	Lens system - magnification 20x
122-602	Lens system - magnification 25x
122-603	Lens system - magnification 50x
122-604	Lens system - magnification 100x

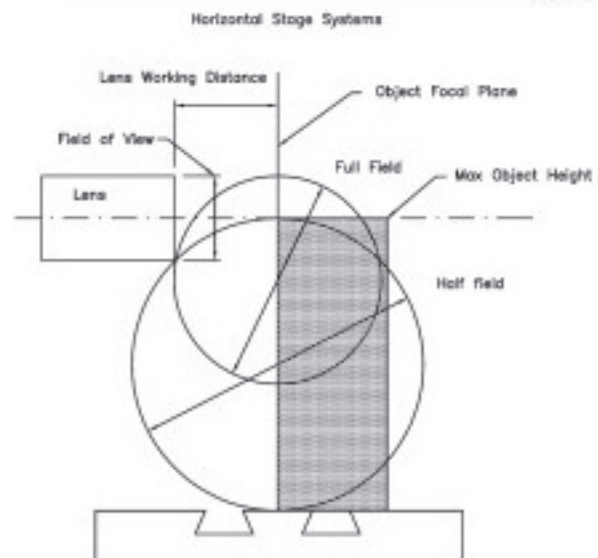

### BATY R14

Code No	Description	Functions
R14-GMR	Horizontal projector with two axis geometric readout	Geometric measurement with LED display
R14-GXL	Horizontal projector with QC200 geometric readout	Geometric measurement functions and tolerancing
R14-FT2	Horizontal projector with Fusion 2D Touchscreen DRO	Windows Touch Screen SW with full reporting
R14-FT2-E	Horizontal projector with Fusion 2D Touchscreen DRO & optical edge detection	As FT2 with optical edge detection

For more information contact [optical@bowersgroup.co.uk](mailto:optical@bowersgroup.co.uk)

## Baty R400 - Profile Projector

The Baty R400 bench mount profile projector with its 400mm screen combines high accuracy non-contact measurement and inspection with a large 300mm x 150mm measuring range.

Choice of digital readouts and automatic profile edge detection. The horizontal light path configuration is ideal for checking machined components that can be secured to the workstage using a range of optional accessories from the Baty fixture family. The robust design of the R400 makes it suitable for both the shop floor and standards room.

### Features

- 400mm (16") screen with 90° crosslines and chart clips
- Profile illumination with halogen lamp and green filter
- Lens magnification choice: 10x, 20x, 25x, 50x and 100x
- Surface illumination (fibre optic)
- Helix adjustment of light source for accurate thread form projection
- Workstage with two machined slots for holding accessories
- Workstage measuring range of 300mm (12") x 150mm (6")
- Digital angle measurement
- 10x lens included
- 0.5 micron resolution

### Available Options

- Internally fitted automatic edge sensor (FT2-E model only)
- Swing over lamphouse to allow clear access to the workstage
- Various electronic measuring systems to suit individual requirements
- Cabinet stand ensures a solid base and provides storage
- Other options include foot switch control

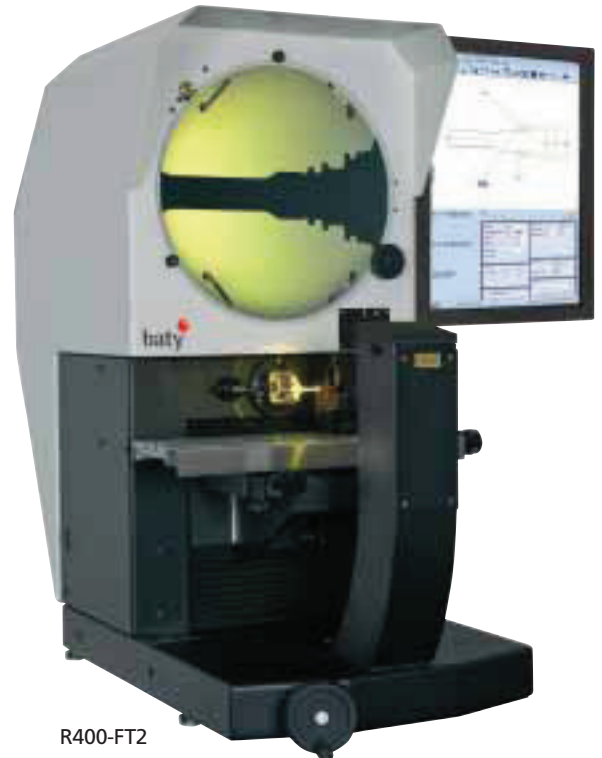

R400-FT2

Horizontal Stage Systems

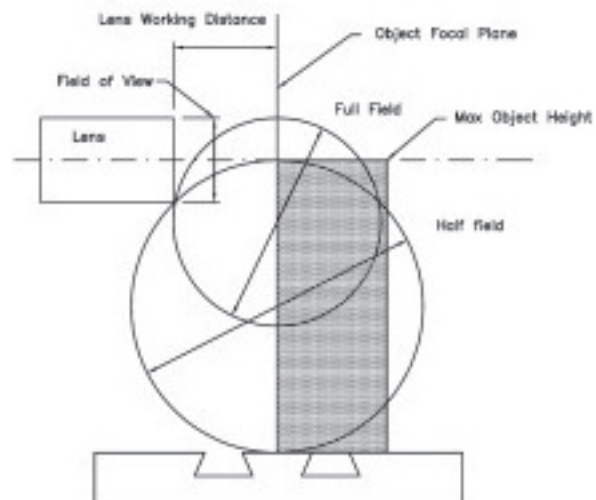

Projector Type	R400				
Magnification	10x	20x	25x	50x	100x
Field of view	40	20	16	8	4
Working Distance	80	82	70	53	43
Maximum	184	185	185	185	143
Working Diameter	179	176	181	147	122

all dimensions in mm

### LENS SYSTEMS

Code No	Description
RH400-087	Lens system - magnification 10x
RH400-088	Lens system - magnification 20x
RH400-089	Lens system - magnification 25x
RH400-090	Lens system - magnification 50x
RH400-091	Lens system - magnification 100x

### BATY R400

Code No	Description	Functions
R400-GMR	Horizontal projector with two axis geometric readout	Geometric measurement with LED display
R400-GXL	Horizontal projector with QC200 geometric readout	Geometric measurement functions and tolerancing
R400-FT2	Horizontal projector with Fusion 2D Touchscreen DRO	Windows Touch Screen SW with full reporting
R400-FT2-E	Horizontal projector with Fusion 2D Touchscreen DRO & optical edge detection	As FT2 with optical edge detection

For more information contact [optical@bowersgroup.co.uk](mailto:optical@bowersgroup.co.uk)

## Baty R600 - Profile Projector

The Baty R600 with its 600mm (24") screen and high specification, presents the capability to make simple comparative non-contact measurement through to complex programmed measuring sequences with SPC capability and automatic edge detection.

The horizontal light beam configuration is ideally suited to large machined or turned workpieces for mounting in vee blocks and centres, or customised features.

### Features

- 600mm (24") screen with 90° cross lines and chart clips
- Heavy duty workstage with 450mm x 200mm (18" x 8") measuring range and 2 machine slots for workpiece holders
- Angular rotation of  $\pm 15^\circ$  on workstage for measuring threadforms or cutting tools
- Vertical 200mm (8") Y axis power driven with joystick control
- Lens magnification choice - 5x (single lens mount), 10x, 20x, 25x, 50x, 100x
- 4 position rotating lens turret for ease of lens changing (excluding 5x)
- Profile illumination with halogen lamp and green filter
- Screen hood and curtains for use in bright ambient light conditions
- Digital angle measurement
- 0.5 micron measurement

### Available Options

- Horizontal axis motorisation via joystick control
- Internally fitted automatic edge sensor to allow the use of overlay charts on an unobstructed screen (FT2-E model only)
- Various electronic measuring systems to suit your individual requirements
- SPC to add to your quality control without the purchase of a separate system (FT2 / FT2-E only)
- 5x lens system as a single lens mount only



R600-FT2-IES  
(Internal Edge Sensor)

Projector Type	R600					
Magnification	5x	10x	20x	25x	50x	100x
Field of view	120 (4.72)	60 (2.36)	30 (1.18)	24 (.94)	12 (.47)	6 (1.72)
Working Distance	245 (9.64)	135 (5.31)	132 (5.19)	106 (4.17)	93 (3.15)	50 (1.96)
Maximum	292 (9.64)	343 (13.50)	343 (13.50)	343 (13.50)	343 (13.50)	195 (7.75)
Working Diameter	406 (18.98)	343 (13.50)	343 (13.50)	343 (13.50)	343 (13.50)	235 (9.25)

all dimensions in mm / (inches)

### LENS SYSTEMS

Code No	Description
202-1850	Lens system - magnification 5x
54-650	Lens system - magnification 10x
202-1852	Lens system - magnification 20x
202-1853	Lens system - magnification 25x
202-1854	Lens system - magnification 50x
202-1855	Lens system - magnification 100x

### BATY R600

Code No	Description	Functions
R600-GMR	Horizontal projector with two axis geometric readout	Basic X Y readout with inch / mm conversion
R600-GXL	Horizontal projector with QC200 geometric readout	Geometric measurement functions and tolerancing
R600-FT2	Horizontal projector with Fusion 2D Touchscreen DRO	Windows Touch Screen SW with full reporting
R600-FT2-E	Horizontal projector with Fusion 2D Touchscreen DRO & optical edge detection	As FT2 with optical edge detection

For more information contact [optical@bowersgroup.co.uk](mailto:optical@bowersgroup.co.uk)

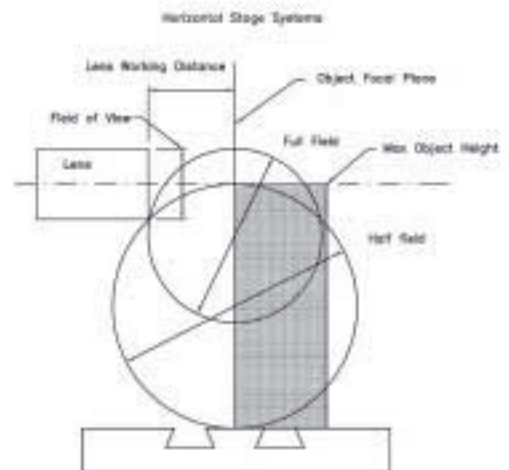



# Baty SM300 - Profile Projector

300mm screen vertical light path projector with multi-function readout unit and printer.

Robust design with full geometric measuring functionality ideal for the shop floor.

## Features

- Top quality profile projector highly versatile and easy to operate
- Large travel range 150mm x 50mm (6" x 2") as standard
- Linear scale stage with 0.001mm resolution
- Fine ground glass screen for clear image with cross hairs
- Screen complete with cross hair lines and chart clips
- Built-in profile and surface illumination
- 10x, 20x, 50x, 100x projection lenses available
- Display-readout unit GMR included in standard delivery

## Available Options

- Projection lens 10x with half reflecting mirror
- Projection lens 20x with half reflecting mirror
- Projection lens 50x with half reflecting mirror
- Projection lens 100x with half reflecting mirror
- Rotary table 360°
- Swivel centre support
- Holder with clamp
- V-block with clamp
- Overlay charts

## Readout

- A simple two axis digital readout for point to point X,Y or R,A measurements
- Absolute or incremental mode with Inch / metric conversion, Zero, preset and print functions. RS-232C serial and parallel ports. Footswitch compatible

	Projection capacity (unit mm)			
Magnification	10x	20x	50x	100x
View field diameter	30	15	6	3
Working distance W	77.7	44.3	24.5	25.3
Max workpiece height H	80	80	80	80
Max workpiece diameter, edge line can be focused on screen centre D	160	130	55	60

## LENS SYSTEMS

Code No	Description
SM300-10X	Lens system - magnification 10x
SM300-20X	Lens system - magnification 20x
SM300-50X	Lens system - magnification 50x
SM300-100X	Lens system - magnification 100x

## BATY SM300

Code No	Description
SM300	Vertical projector with geometric readout

For more information contact [optical@bowersgroup.co.uk](mailto:optical@bowersgroup.co.uk)

## GMR Readout Features

- Geometric measuring functions including skew
- Integrated screen protractor display
- RS-232 data output for PC or printer
- Cartesian / polar coordinates
- Zero, abs/inc mode
- Inch / metric selection
- Bright easy read LED display



SM300

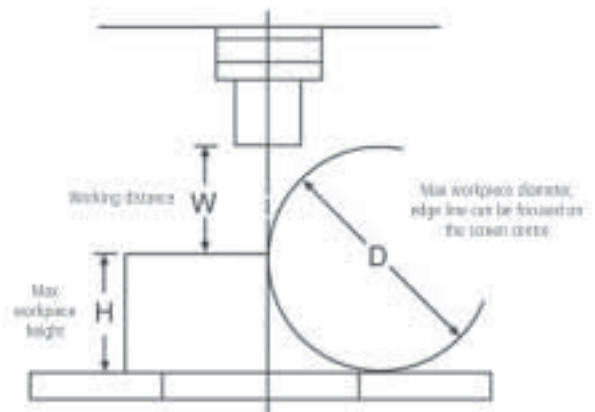

## Baty SM350 - Profile Projector

The SM350 is an all new design. This vertical 350mm / 14" screen bench projector features a large, heavy duty high precision workstage with 250mm x 125mm measuring range and 0.5 micron resolution. Another new feature is the option of a three lens turret for instant lens changes without re-calibration.

### Features

- Fully usable 340mm screen
- Digital screen protractor
- Built in helix adjustment
- Sturdy all-steel design
- Heavy duty cross roller bearings
- Quick release 'X' and 'Y' travel
- Erect image
- Easy-view vertical screen
- Large stage travel 250mm (10") x 125mm (5")
- Rotating chart clips
- Fibre optic illumination for surface measurement
- Includes 10x lens
- 0.5 micron resolution

### Available Options

- Automatic screen-mounted edge sensing (FT2-E model only)
- Heavy duty cabinet
- 3-position rotating lens turret



SM350-FT2

Projector Type	SM350					
Magnification	10x	20x	25x	50x	100x	
Field of view	35	17	14	7	3	
Working Distance	81	38	31	15	28	
Maximum	half field	220	162	52	51	140
Working Diameter	full field	171	130	75	37	97
Maximum Height Object		114	113	106	111	103

all dimensions in mm

### LENS SYSTEMS

Code No	Description
122-600	Lens system - magnification 10x
122-601	Lens system - magnification 20x
122-602	Lens system - magnification 25x
122-603	Lens system - magnification 50x
122-604	Lens system - magnification 100x

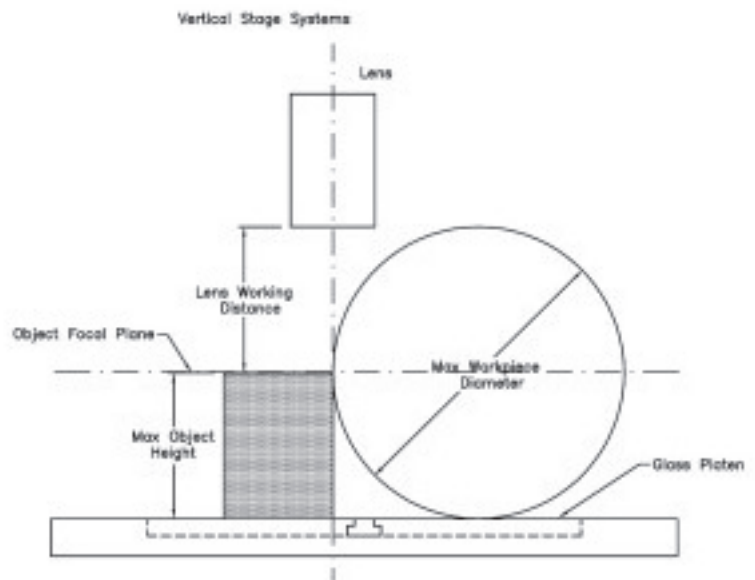

### BATY SM350

Code No	Description	Functions
SM350-GMR	Vertical projector with two axis geometric readout	Geometric measurement with LED display
SM350-GXL	Vertical projector with QC200 Geometric Readout	Geometric measurement functions and tolerancing
SM350-FT2	Vertical projector with Fusion 2D Touchscreen DRO	Windows Touch Screen SW with full reporting
SM350-FT2-E	Vertical projector with Fusion 2D Touchscreen DRO & optical edge detection	As FT2 with optical edge detection

For more information contact [optical@bowersgroup.co.uk](mailto:optical@bowersgroup.co.uk)



## Baty SM20 - Profile Projector

The Baty ShadoMaster SM20 is a vertical light path floor standing profile projector with a 500mm / 20" screen and features a large heavy duty high precision workstage with 250mm x 125mm measuring range and a 0.5 micron resolution.

### Features

- 500mm screen with 90 degree crosslines and chart clips
- Angled screen for easy viewing
- Profile illumination with halogen lamp and green filter
- Single lens mounting
- Lens magnification choice: 5x, 10x, 20x, 25x, 50x and 100x
- Helix adjustment of light source for accurate thread form projection
- Large stage travel 10" (250mm) x 5" (125mm)
- Digital angle measurement
- 0.5 micron resolution

### Available Options

- Screen hood and curtains with generous proportions for use in bright ambient light conditions
- Automatic edge sensing
- Surface illumination through twin fibre optics for bright full colour surface inspection
- 3 position lens turret for easy lens changing (excluding 5x)
- Various electronic measurement systems to suit your individual requirements
- SPC to add to your quality control without the purchase of a separate system
- 5x lens system as a single lens mount only



SM20-GXL

Projector Type	SM20					
Magnification	10x	20x	25x	25x	50x	100x
Condenser	L	L	L	S	S	S
Field of view	50	25	20	20	10	5
Max diameter	200	200	200	200	180	85
Max focal pane height (profile lighting)	205	203	218	254	240	195
Max end mill height (surface lighting)	150	153	153	153	150	150

### LENS SYSTEMS

Code No	Description
202-1850	Lens system - magnification 5x
54-650	Lens system - magnification 10x
202-1852	Lens system - magnification 20x
202-1853	Lens system - magnification 25x
202-1854	Lens system - magnification 50x
202-1855	Lens system - magnification 100x

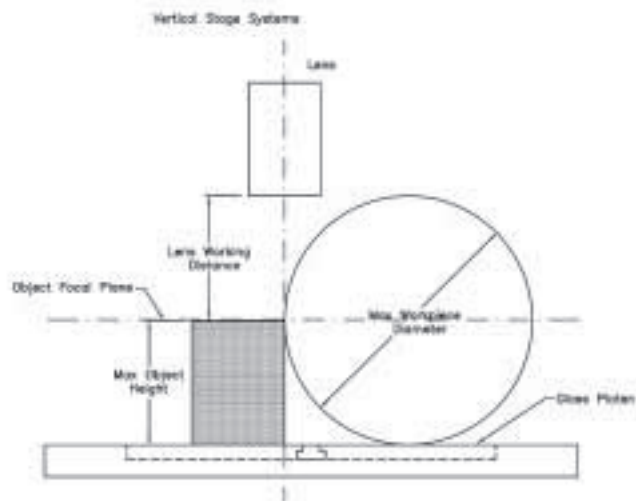

### BATY SM20

Code No	Description	Functions
SM20-GMR	Vertical projector with two axis geometric readout	Geometric measurement with LED display
SM20-GXL	Vertical projector with QC200 Geometric Readout	Geometric measurement functions and tolerancing
SM20-FT2	Vertical projector with Fusion 2D Touchscreen DRO	Windows Touch Screen SW with full reporting
SM20-FT2-E	Vertical projector with Fusion 2D Touchscreen DRO & optical edge detection	As FT2 with optical edge detection

For more information contact [optical@bowersgroup.co.uk](mailto:optical@bowersgroup.co.uk)

## Baty Readout Options

The readout options from Baty include a fully programmable unit with geometrical functions and a software module allowing direct connection to a PC. All units are fully compatible allowing upgrades as required.

### GMR Readout

- Geometric measuring functions including skew
- Integrated screen protractor display
- RS-232 data output for PC or printer
- Cartesian / polar coordinates
- Zero, abs/inc mode
- Inch / metric selection
- Bright easy read LED display



### GXL Readout

- Graphical display of measured feature
- Radius, angle, line, point, skew
- Inch, metric, polar, cart
- Data output to PC/printer
- Store inspection routines to prompt operator
- Tolerancing
- Multi-language menu
- On-screen help



### Fusion Touch Readout

**FT2:** Complete TOUCH SCREEN DRO with 2D Fusion Touch software for projectors with full geometric functionality. Graphical view of measured part can be printed as a fully dimensioned drawing with geometric tolerances. Other graphics include form error and SPC charts. Full reporting capability includes tabulated details with pass / fail analysis, auto link to Excel and auto sequence programming feature. SPC and best fitting to dxf (overlay). Windows O/S and built in 19" portrait touch screen monitor in a rugged all steel housing.

**FT2-E:** Complete TOUCH SCREEN DRO with 2D Fusion Touch software as above. Built-in optical edge detection allows data points to be taken 'on the fly' as the projected image is passed under the screen-mounted fibre optic sensor. An internally mounted edge sensor is available as an option on all 'R' series projectors.

**Note:** FT2 and FT2-E DROs are available to retrofit to customers' projectors, of any make.

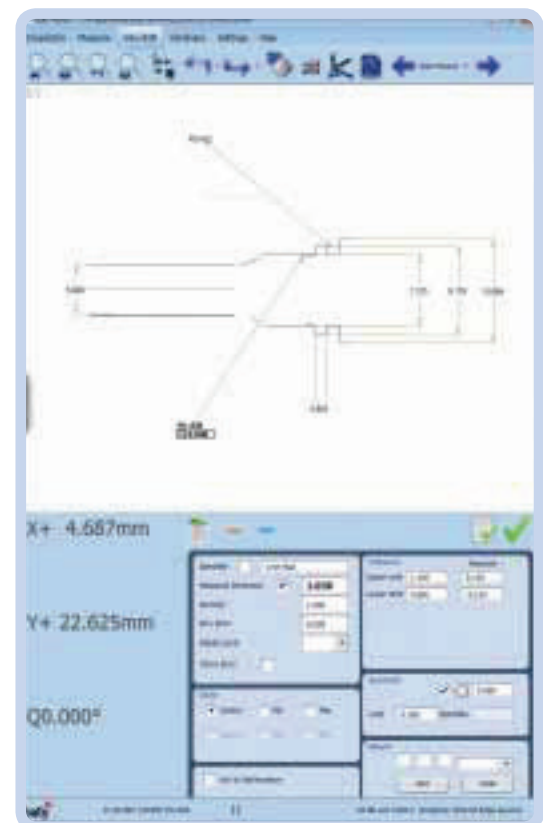

For quotations or technical assistance contact  
[optical@bowersgroup.co.uk](mailto:optical@bowersgroup.co.uk)



# Baty Options & Accessories - Profile Projector



SA-527



SA-250



52-602



SA-256 / SA-258



52-701 / 52-604



SA-152



52-600 / 52-603



SA-260

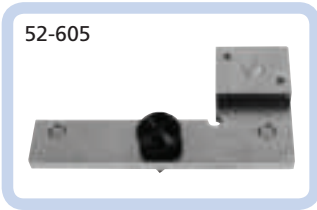

52-605



SA-542 Large Vee Blocks and Centres



SA-543 Riser Blocks



Rotary Glass Stage SA-245-2

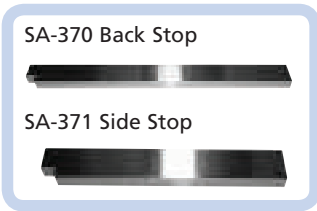

SA-370 Back Stop

SA-371 Side Stop



SA-196-EXT Dual Vee Blocks and Centres

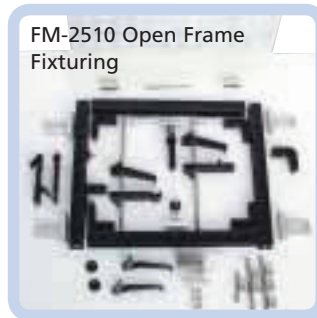

FM-2510 Open Frame Fixturing

## R14 / R400 ACCESSORIES

Code No	Description
202-1327-1	Footswitch for GXL
ABF5001	Footswitch for FT2 DRO
52-371	Protective cover – R14
350-035	Protective cover - R400/SM350
SA-328	Cabinet stand
SA-250	Iris diaphragm
SA-256	Vee blocks
SA-258	Spring loaded centres
SA-259	Riser blocks 38mm ( 1 1/2") for SA-256
SA-152	Vice stage and vice
SA-260	Swivel vice
SA-276	Single vee and clamp (Vee parallel to optic axis)
SA-153	Fixture base
SA-527	Glass plate work holder

## R600 ACCESSORIES

Code No	Description
SA-551	Iris diaphragm for SM350/R600
SA-542	Large vee blocks and centres
SA-543	Riser blocks
SA-614	Large vice stage and vice
SA-527	Glass plate work holder
SA-617	Heavy duty rotating vice
SA-733	Swing over lamphouse
SA-606	Screen chart rest bar

## FIXTURE FAMILY ACCESSORIES

Code No	Description
52-600	Self centering vice
52-601	Dual axis vee block and clamp to Ø 15mm
52-602	Dual axis vee block and clamp to Ø 30mm
52-603	Precision rotary base
52-604	Universal base
52-605	Precision ground steel alignment feature
52-701	Dual axis vee block fitted with side base

## SM350 / SM20 ACCESSORIES

Code No	Description
SA-245-2	Rotary glass stage
SA-370	Back stop
SA-371	Side stop
SA-196-EXT	Dual vee block and centres
FM-2510	Open frame fixturing for 2510 stage
SA-551	Iris diaphragm for SM350/R600
350-035	Protective cover - R400/SM350

For more information contact [optical@bowersgroup.co.uk](mailto:optical@bowersgroup.co.uk)



## Reprorubber - Metrology Grade Casting Material

Reprorubber offers numerous advantages over other hard-copy replicating materials:

- Quick casting – zero shrinkage
- No release agent required – will not stick to part
- Surface finish replication is exact with excellent optical properties easily checked on an optical comparator or video inspection machine
- Copies can be re-copied from original mould
- Replicas are permanent – will not leach out, ooze out, or gas out
- No more 16 hour cure time as with RTV silicones
- More accurate than all other RTV compounds

### Original Reprorubber® Thin Pour - Final Colour: LIGHT GREEN

For internal-shape applications where a thin pour will completely fill the cavity without voids. A complete replica casting is quickly formed.

- Manipulation time is approx 2 minutes and cure time is approximately 10 minutes
- Start to finish: approximately 12 minutes
- Kits include graduated mixing cups, wooden spatulas and instructions

### Original Reprorubber® Quick Setting Putty - Final Colour: LIGHT BLUE

Roll two equal-sized balls of catalyst putty and base putty and simply knead them together like dough. Excellent for external shapes.

Simply spread over master pushing down with fingers and wait for cure 8-10minutes. Manipulation time is 1 to 2 minutes. Therefore 12 minutes start to finish.

You can also cast internal shapes and cavities but some pressure should be applied such as a weighted object on top.

### New Reprorubber® Orange – Medium Body Pre-filled Cartridges - Final Colour: ORANGE

New Medium Body (Medium Viscosity – Medium Durometer) casting material ideal for both internal and external applications. Disposable pre-filled dual barrel 50ml cartridges can quickly dispense casting material utilising the REPRO-MIX II Gun System.

- Mix time: 15-30 seconds and cure time is 5-6 minutes
- Start to finish: 6-8 minutes

### Quick Dispense Cartridge System Kit

Contains everything you need to easily create highly accurate, zero shrinkage replicas.

Each kit includes 1 each:

- Repr-Mix II reusable dispensing gun
- 6 each 50ml pre-filled Reprorubber disposable cartridges
- 15 disposable mixing nozzles
- 2 micro injector snap-on nozzles
- Deluxe fitted carrying case



16305





# Reprorubber - Metrology Grade Casting Material

## Applications - You can take impressions of:

- All metals
- Non metals
- Paper or cardboard items
- Wood, marble etc
- All plastics
- Rubber
- Ceramic and glass items

## Physical advantages over the hard-copy replicas:

- Replica is easy to remove – even if they are under cuts or grooves
- Cross-sectioning of replica is easily accomplished with a knife or razor
- It can then be checked on an optical comparator or microscope
- Surface finish replication is exact with excellent optical properties
- Reprorubber copies can be re-copied (copy from a 'female mould' yields a male-shaped replica)
- Replicas are permanent – will not leach or ooze out nor gas out
- No more 16 hour cure time as with RTV silicones
- More accurate than all other RTV compounds
- Reprorubber putty will withstand up to 600°F (or more)

## Other Uses Include:

- Prototypes of rubber type components such as gaskets, washers, etc
- Making joints where flexibility is required
- As a mask for high temperature plasma spray of metallic coatings
- Fixturing where semi-rigid structure is desired

	REPRORUBBER THIN POUR 15-30 seconds	REPRORUBBER MEDIUM BODY ORANGE 15-30 seconds	REPRORUBBER QUICK SETTING PUTTY Approximately 1 minute
Working Time (Manipulation Time)	2 minutes	2.5 minutes	1-2 minutes (from beginning of mix)
Setting Time (at room temperature)	10-15 minutes	5-6 minutes	8-10 minutes
Permanent Deformation	0.2%	0.3%	0.3%
Dimensional Stability	less than 0.50%	less than 0.40%	less than 0.25%
Tear Strength	44 pounds per sq. inch	300 pounds per sq. inch	105 pounds per sq. inch
Elongation	60% at break	70% at break	6.3% at break
Durometer (Shore A-2)	30 (at 15 minutes)	40 (at 10 minutes)	50 (at 7 minutes)
Temperature Stability	1 week @ 23°C (72°F)	1 week @ 23°C (72°F)	1 week @ 23°C (72°F)
Detail Reproduction	EXCELLENT	EXCELLENT	EXCELLENT

## REPRORUBBER

Code No	Description
<b>Ordering Complete Kits:</b>	
16300	Reprorubber Thin Pour (Green) Quick Dispense Cartridge System Kit Complete
16305	Reprorubber Orange (Medium Body) Quick Dispense Cartridge System Kit Complete
16309	Reprorubber Combo Kit Quick Dispense Cartridge System Kit, Includes 3 each Thin Pour & 3 each Orange
<b>Ordering Original Mix Your Own Kits:</b>	
<b>Original Reprorubber® Thin Pour - Final Colour: LIGHT GREEN</b>	
16116	Thin Pour 130ml Mix Your Own Trial Kit - Final Colour: Light Green
16135	Thin Pour 380ml Mix Your Own Kit - Final Colour: Light Green
16137	Case of 10 each 380ml Mix Your Own Kits - Final Colour: Light Green
<b>Ordering Original Mix Your Own Kits:</b>	
<b>Original Reprorubber® Quick Setting Putty - Final Colour: LIGHT BLUE</b>	
16129	220ml Trial Quick Setting Putty Mix Your Own Kit - Final Colour: Light Blue
16130	1 3/4 lb (520ml) Introductory Mix Your Own Kit - Final Colour: Light Blue
16131	7lb (2150ml) Economy Mix Your Own Kit - Final Colour: Light Blue
<b>System Refills</b>	
16301	Reprorubber Thin Pour (Green) 50ml Cartridge, 1 each
16302	Reprorubber Thin Pour (Green) 50ml Cartridges, 6 pack
16306	Reprorubber Orange (Medium Body) 50ml Cartridge, 1 each
16307	Reprorubber Orange (Medium Body) 50ml Cartridges, 6 pack
16311	Repro-Mix II Dispensing Gun (reusable)
16313	Repro-Mix II Helix Mixing Nozzles, 15 Pack
16316	Repro-Mix II Helix Mixing Nozzles, 100 Pack
16315	Quick Dispense Cartridge System Fitted Case (without contents)
16314	Micro Injector Snap-On Nozzle, Pack of 15



16301



16306

For more information contact [optical@bowersgroup.co.uk](mailto:optical@bowersgroup.co.uk)